



Fundamentals of Bolted Joint Design Training Topics

*Training delivered by Matrix Engineering, an approved
provider of Bolt Science® Training.*



© Copyright Bolt Science Limited 2024 and: Information contained in this document has been obtained and developed by Bolt Science Limited from sources considered to be reliable. However, neither Bolt Science nor its authors guarantee the accuracy or completeness of any information published herein and neither Bolt Science nor its authors shall be responsible for any errors, omissions, or damages arising out of the use of this information.

Following is a summary of potential training topics that can be delivered to suit a company's or organization's specific requirements. Customization may include unique fastener sizes, materials or conditions, particular problems, or other topics the client provides.

Introduction to Course

- *Introductions*
- *Primary Bolted Joint Application Types*
- *Bolted Joints – More to it than you may have thought!*
- *Dunning-Kruger Effect*
- *Reference Books and Standards*

Introduction to Threaded Fasteners

- *Common thread and fastener terminology.*
- *Common head styles, thread points, and nut styles.*
- *Background to modern threads - the roles of Whitworth and Sellers and the development of the modern thread form.*
- *Learn the difference between a fine and coarse thread and the advantages/disadvantages of each.*
- *The basic profile of unified and metric thread forms.*
- *Thread tolerance positions and grades and the tolerance classes.*

Introduction to the Strength of Threaded Fasteners

- *The principles of bolt elongation, bolt stress, load, and gasket stress.*
- *Yield, tensile strength, and proof load properties.*
- *Details of the common bolt and nut specifications and markings.*
- *Nut/bolt combinations, nut strength versus bolt strength.*
- *Relationships between bolt size, area, stress, bolt elongation, and load.*
- *Determination of the stress area of a thread.*
- *Washer purposes and requirements.*

Overview of Fastener Failure Mechanisms and Causes

- *Overview of the ways threaded fasteners can fail.*
- *Introduction to the common fastener failure mechanisms.*
 - *Combined stress fracture*
 - *Torsional shear fracture*
 - *Transverse shear fracture*
 - *Galling*
 - *Stripping*
 - *Compressive yield of joint*
 - *Fatigue fracture*
 - *Tensile fracture*
 - *Wear failures*
 - *Hydrogen embrittlement*
- *Common failure causes of dynamically loaded joints.*

Thread Stripping

- *Identify the cause of thread stripping.*
- *Shear cylinder concepts.*
- *Estimating the shear area of an internal or external thread.*
- *How the tapping drill size affects the strength of the bolt thread.*
- *Example calculation of stripping in a large plate.*
- *Stripping calculations in nuts and thin wall tubes.*
- *Long thread engagements.*
- *Thread inserts.*
- *Weld nuts.*

Compressive Stress under Bolt Head & Nut Face

- Explanation of compressive stress.
- The bolted joint 'stress cone'.
- Simplified equation to calculate compressive stress.
- The effect of the washer.
- Example calculation & demonstration.
- Slotted joint plates.

Fatigue Failures in Threaded Fasteners

- Understand the causes of fatigue to recognize this type of failure.
- Learn about the S-N diagram and the endurance strength of a threaded fastener.
- The different approaches that can be used to establish the endurance strength of a pre-tensioned threaded fastener.
- Common fatigue fracture locations.
- Effect of head/nut angularity on fatigue life.
- Common methods of reducing risks of fatigue fractures.

Introduction to Joint Diagrams

- Bolt and joint stiffness calculations.
- Explanation of basic joint diagram.
- Comparison of hard and soft joints.
- Effect of bolt preload and applied axial loads.
- Example problem. (time permitting)
- Calculation of applied load resulting in joint separation.
- Load factor explanation and calculation.
- Effect of load introduction location.

Methods of Tightening Threaded Fasteners

- Overview of the methods used to tighten bolts.
- Load-angle of turn graph for a bolt tightened to failure.
- Torque control tightening.
- Torque control plus angle monitoring tightening.
- Torque plus angle control tightening.
- Yield control tightening.
- Direct tensioning.
- Tension-indicating methods using load-indicating bolts and washers.
- Application of ultrasonic technology and other instrumentation in bolt tightening.

Torque Control Tightening

- What is meant by a tightening torque?
- How torque is absorbed by a nut/bolt assembly.
- The relationship between the tightening torque and the resulting bolt preload (tension).
- The factors which affect the torque-tension relationship.
- The nut factor method of determining the correct tightening torque.
- The full torque-tension equation.
- Example calculation to determine the tightening torque
- Scatter in the bolt preload resulting from friction variations.
- Prevailing torque fasteners and how it affects the torque distribution and what is the correct torque to use.
- Tests to determine the coefficient of friction of threaded fasteners.
- Combined stress during torque tightening.

Tightening Tools

- Manual torque wrenches
- Impact drivers
- Pulse tools
- Nut runners: Non-reporting / Reporting
- Fixtured nut runners

Demonstrations with a Skidmore Device

- Demonstration of the preload scatter achieved using torque tightening.
- Effect of repeated tightening of Electro-Plate Zn bolt and nuts.
- Demonstration of Torque-Angle Tightening (time permitting)
- Demonstration of compressive yield failure and the effect of the washer.

Tightening Procedures

- Problems associated with the tightening of the multi-bolt joint.
- Elastic interaction.
- Single pass tightening sequence.
- Two-pass and multi-pass tightening sequences.
- Tightening sequences for non-circular bolted joints.
- Tests investigating the effects of elastic interaction.
- Use of multiple tightening tools.

Torque Auditing

- Torque Auditing – Why is it done?
- Torque auditing methods
 - On torque methods
 - Off-torque method
 - Marked socket/fastener method
- Torque audit test approaches
- Issues with torque auditing
- Witness Marking/Pointers

Relaxation Loosening

- Explanation of relaxation
- Explanation of embedment
- Current understanding of embedment and parameters that affect it.
- Embedment and the Joint Diagram
- Loss of preload due to embedment – springs in series.
- Reference values from VDI 2230.
- Effect of joint thickness on embedment and other forms of relaxation.
- Effects of paint in bolted joints.
- Methods of reducing relaxation.

Self-Loosening of Threaded Fasteners

- Appreciate the forces acting on the threads that tend to self-loosen a fastener.
- The inclined plane analogy.
- Junker's theory on self-loosening of fasteners and why fasteners self-loosen.
- The Junkers transverse vibration test.
- The phases of self-loosening.
- Preload decay curves of various locking devices resisting vibrational loosening.
- Micro slip in joints resulting in self-loosening.
- Conclusions from the research and methods of reducing the likelihood of loosening.

Vibrational Detachment of Threaded Fasteners

- A quick overview of research on dynamic analysis of threaded fasteners subjected to axial vibration.

Bolts Loaded in Direct Shear

- Friction grip and direct shear bolted joint designs.
- Issues with bolts loaded in direct shear.
- Shear capacity in direct shear.
- Example calculation - direct shear loading.
- Joints consisting of multiple bolts in series.
- Joints sustaining direct shear and axial loading.
- Tear out of joint plates.
- Example problem.
- Potential problems resulting from direct shear joints with dynamic loads.

Shear Loading of 'Friction Grip' Bolted Joints

- Explanation of friction grip.
- What is meant by an eccentric shear load?
- Understand the slip process that can occur with shear-loaded joints.
- Learn what the instantaneous center of rotation means for a bolt pattern.
- Simplified equations to estimate the shear load at individual bolted joints.
- Example calculations.

Combined Tension and Shear Loading of 'Friction Grip' Bolted Joints

- Joints that carry bending moments.
- Explanation of the neutral axis.
- Estimating reactions in bolted joints in flexible joints.
- Estimating reactions in bolted joints in rigid joints.
- Placement of the neutral axis.
- Example calculations.

Preload Requirement Charts

- A simple method to evaluate bolted joints that will catch most bolting issues.
- Determining the maximum and minimum preloads (capacity)
- Determining the total force requirement for the joint (demand)
- Example calculations.
- Ways in which a bolting design problem can be resolved.
- Statistical considerations in bolted joint design.

Simplified Design Guide

- Systematic step-by-step guide to aid designers and design engineers in designing a bolted joint from scratch using simplified and conservative assumptions.

Optional In-Class Projects

- In a class project, which can be solved in teams, individually by students or the instructor.
- Re-design of the front caster wheel mounting bracket bolted joint.
- Discussion about the assumptions and how to apply engineering judgment to decide if the solution is 'good enough'.

Fasteners at Low or Elevated Temperatures

- Overview of the effect of decreasing or increasing the temperature that the joint was assembled.
- Temperature ranges of common bolting materials.
- The effect of differential thermal expansion
- Transitory temperature effects.
- Effect of temperature on the yield strength of common bolting materials.
- Effect of temperature on the modulus of elasticity.
- Stress relaxation and the effect on the bolt preload.
- Example calculation accounting for differential thermal expansion and stress relaxation.

Fastener Finishes and Corrosion

- Background and corrosion mechanisms.
- Common corrosion protection methods.
- The galvanic series and barrier and sacrificial protection.
- Common fastener coatings
- Effect of the coating thickness on thread dimensions.
- Limits of coating thickness on the threads.
- Salt spray testing and the performance of various finishes.

Galling of Threaded Fasteners

- Background and explanation of galling.
- Types of fastener material and finishes susceptible to galling.
- Examples of thread galling.
- Approaches that are used to prevent/minimize galling.

Fatigue Life Prediction of Bolts

- Overview of Fatigue Life Prediction of Bolts
- Endurance Limit Explanation
- Endurance Limit Values – Bickford
- Endurance Limit Calculations using Marin Equation – Shigley
- Endurance Limit Values for SHCS – Unbrako
- Endurance Limit Values in VDI 2230 Part 1
- Commentary on Fatigue Guidelines in ASME B&PVC
- Treatment of Fatigue in NASA 5020B

Overview of Bolted Joint Analysis and FEA Methods

- Commercially Available Software
- Typical Calculations in BJA Software
- Where FEA Shines
- Load Applied to Bolted Joint vs. the Bolt
- FEA Best Practices
- Common Modeling Techniques
- Advantages/Disadvantages of each method.
- Validation of FEA and Reporting
- Factors often missed in FEA.

Interpretation of FEA Results for Fatigue Life Prediction of Bolts

- FEA is Superior to Analytical Methods for Fatigue
- The theoretical loaded cases which cause bending in bolts.
- Interpretation of FEA Results in Fatigue Calculations
- Typical Steps to Use FEA Results in Fatigue Calculations

Interpretation of FEA Results to Predict Joint Slip Failure Mechanisms

- Rigid Body Model for Slip in Bolted Joints
- Elastic Model for Slip in Bolted Joints
- Simplified FEA Model
- Failure Mechanisms Associated with Joint Slip
- Fretting at the Joint Interface
- Self-loosening of the Threaded Fastener
- Bending Fatigue Fractures

Bolted Joint FEA Example: A Comparison of Methods and Results

- Simple Rigid Body – Free Body Diagram
- Various Ways to Simulate Structure with FEA
- Pre-Loaded - 3D Bolts with Contact
- Preloaded – Beams with Contact
- Stiff Beams – No Contact
- Using FEA Simulation Results for Evaluating Bolt Fatigue

Hydrogen Embrittlement of Fasteners

- Background of hydrogen embrittlement.
- Fracture characteristics associated with this type of failure.
- The two forms of hydrogen-induced cracking.
- The cause and mechanism of hydrogen embrittlement.
- Stress corrosion cracking.
- Risk reduction strategies.

Typical Questions Addressed in the Training

- What tightening torque should be applied to the fasteners?
- How do you quantify the bolt preload scatter associated with the tightening process in a calculation methodology?
- Should the nut or bolt be tightened?
- What are the advantages of using other tightening methods rather than torque control?
- What ways to check the 'tightness' of a previously tightened fastener?
- Is the drive joint shown likely to fail under the given dynamic loading condition?
- What is likely the problem, and how can the issue be rectified?
- Can it be anticipated that the joint will fail due to?
 - Insufficient preload?
 - Bolt Fatigue Failure?
 - Thread Stripping?
 - The bolts/nuts self-loosening?
 - Bolt Overload?
 - Thread Stripping?
- If a problem is identified, how can the joint be modified to fit for purpose?
- How can the effects of joint relaxation be quantified at the design stage?
- Do I need to use a fastener-locking device?
- Why a stronger bolt is not necessarily better?
- Is it better for a bolt to fail by tensile fracture during the tightening process or sustain thread stripping?
- Under what specific circumstances does a fastener self-loosen, and how can it be prevented?
- Why are many locking devices that research indicates are ineffective still being used?
- What tests can be completed to validate this joint?

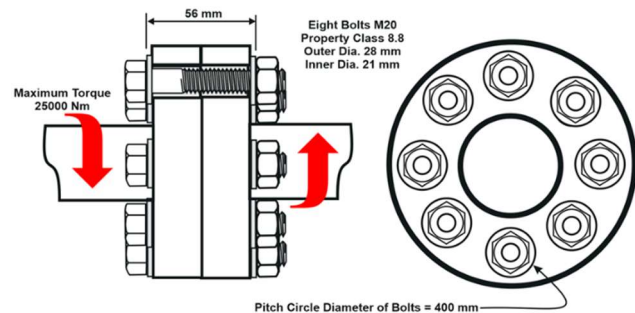



Fundamentals of Bolted Joint Design

Training Topics

©Copyright Bolt Science Limited 2024

Training Course Instructor

Jon Ness, PE, will present the training course. Jon has over 32 years of engineering and design experience in developing mobile equipment components and sub-systems, including dynamically loaded bolted joints. His work has included the design of multiple gearboxes, powertrain systems, engine installations, and developing test and validation plan strategies. He has taught numerous classes related to Failure Modes and Effects Analysis and Bolted Joint Design for design engineers.